

Glue parts numbered in red to 0,5mm card

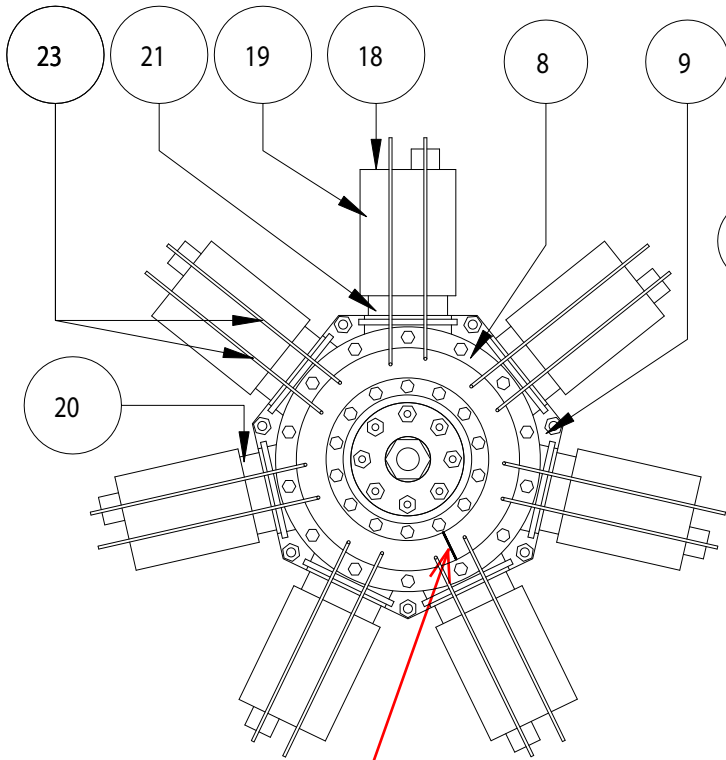

note position of joint part 7

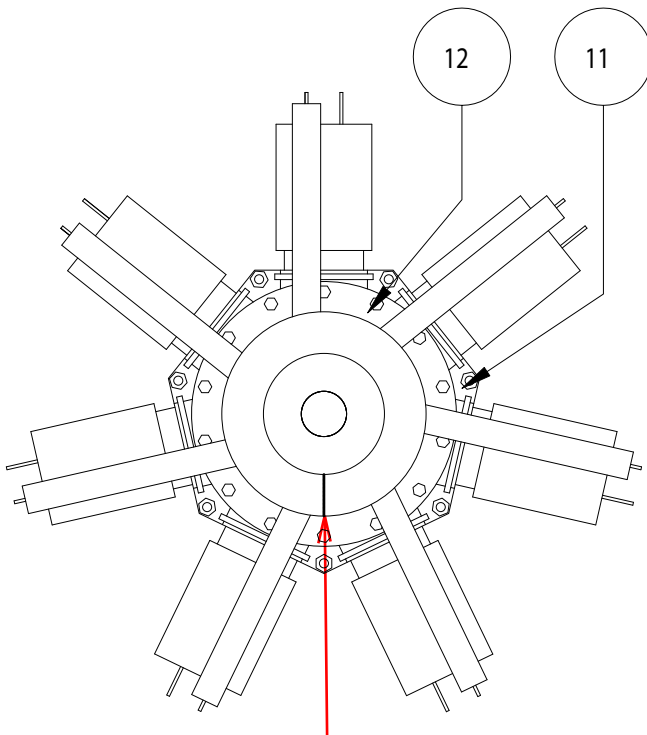
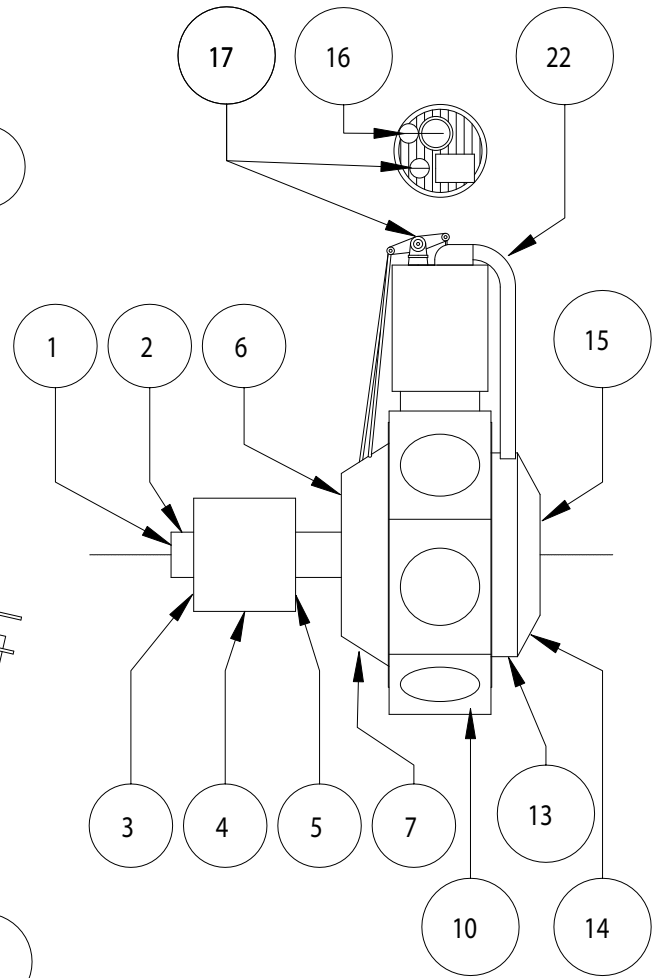

note position of joint parts 13 & 14

Clerget 7Z 1913

bore 120mm

stroke 150mm

displacement 11.869cc

80hp @1250rpm

weight 125kg

constructed at Clerget-Blin

mounted on airplanes of Clément-Bayard,
Deperdussin, Caudron, hydravion Donnet

Avro 504, Bristol Scout, RAF BE8,

RAF SE2, Sopwith Pup.

(source Gérard Harfmann)

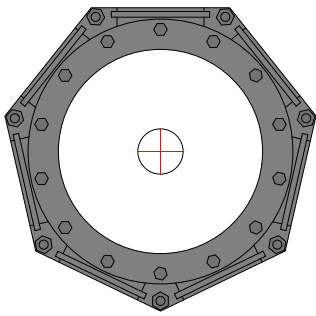

11

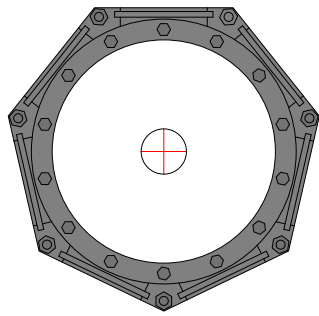

9

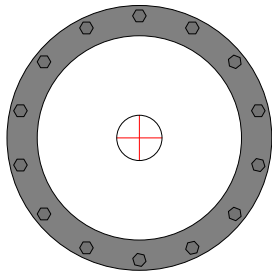

12

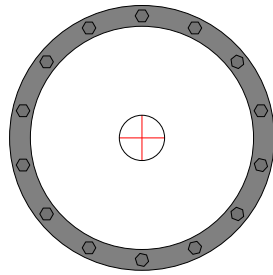

8

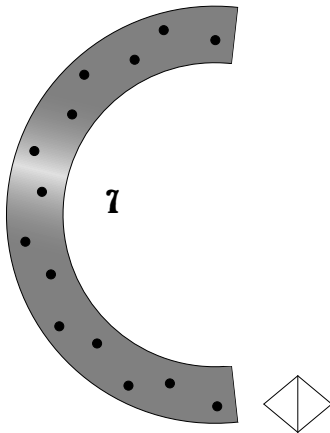

7

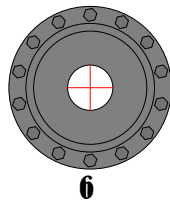

6

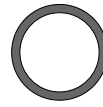

20

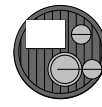

18

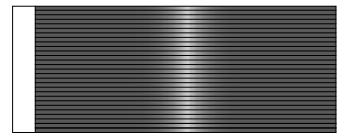

19



21

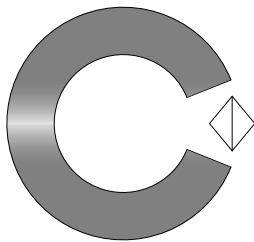
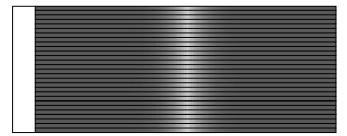
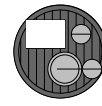
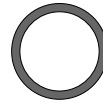
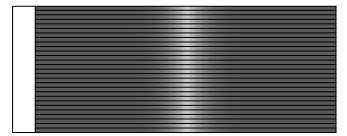
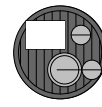
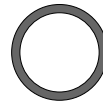
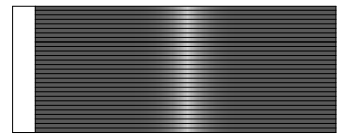
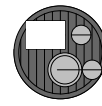
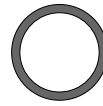
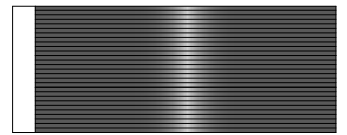
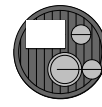
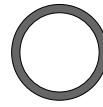
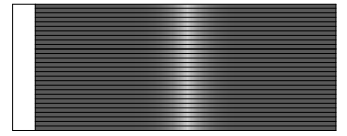
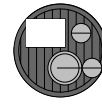
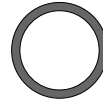

14

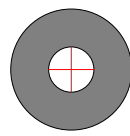

15

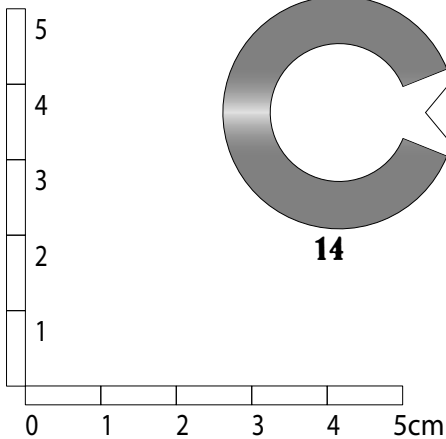

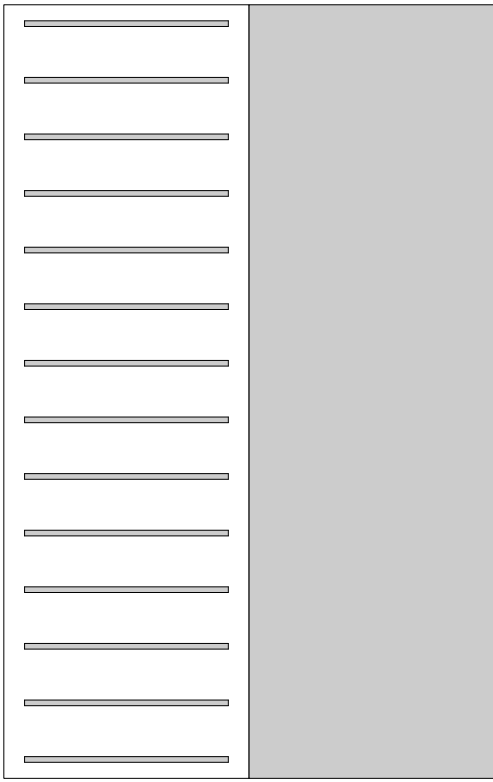

23

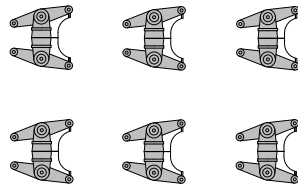

17

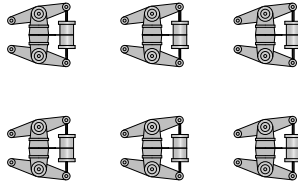

16

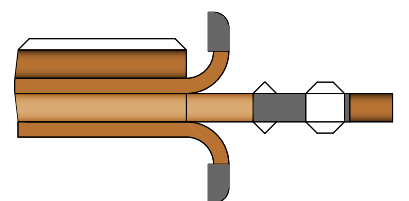
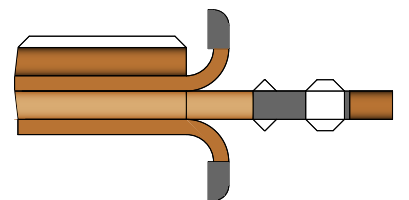
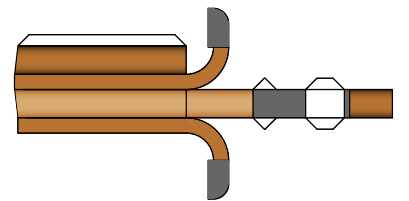
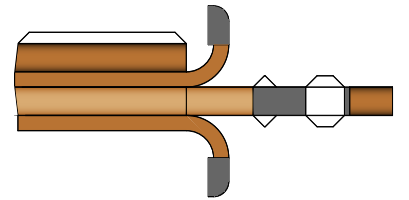
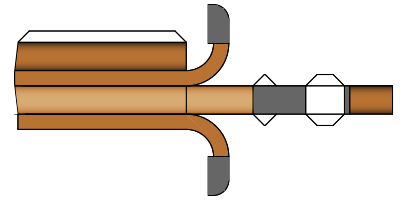
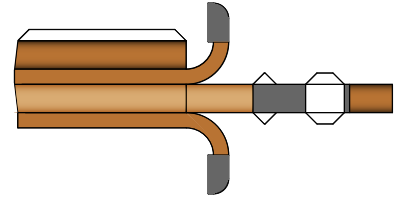
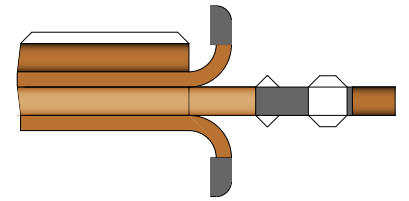

22

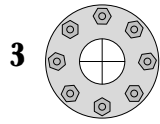

3

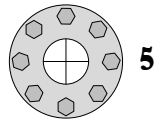

5



4

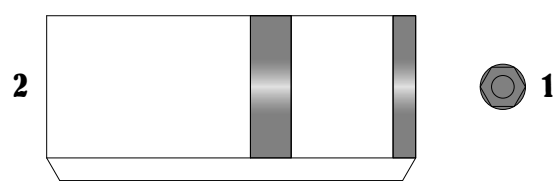

2

1

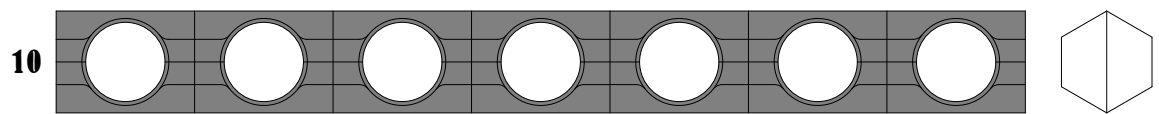
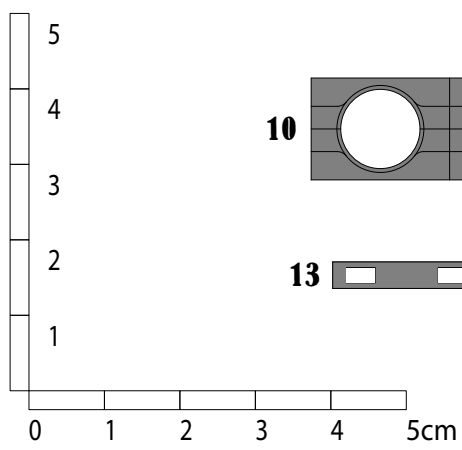

10



13

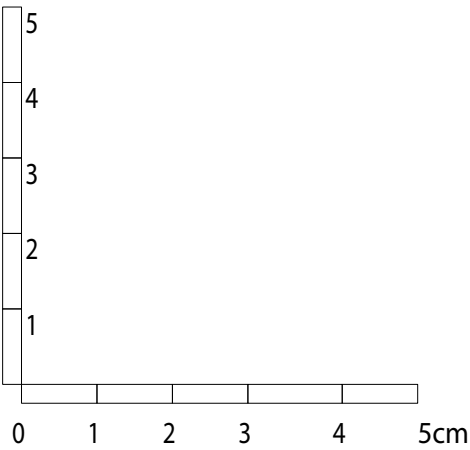
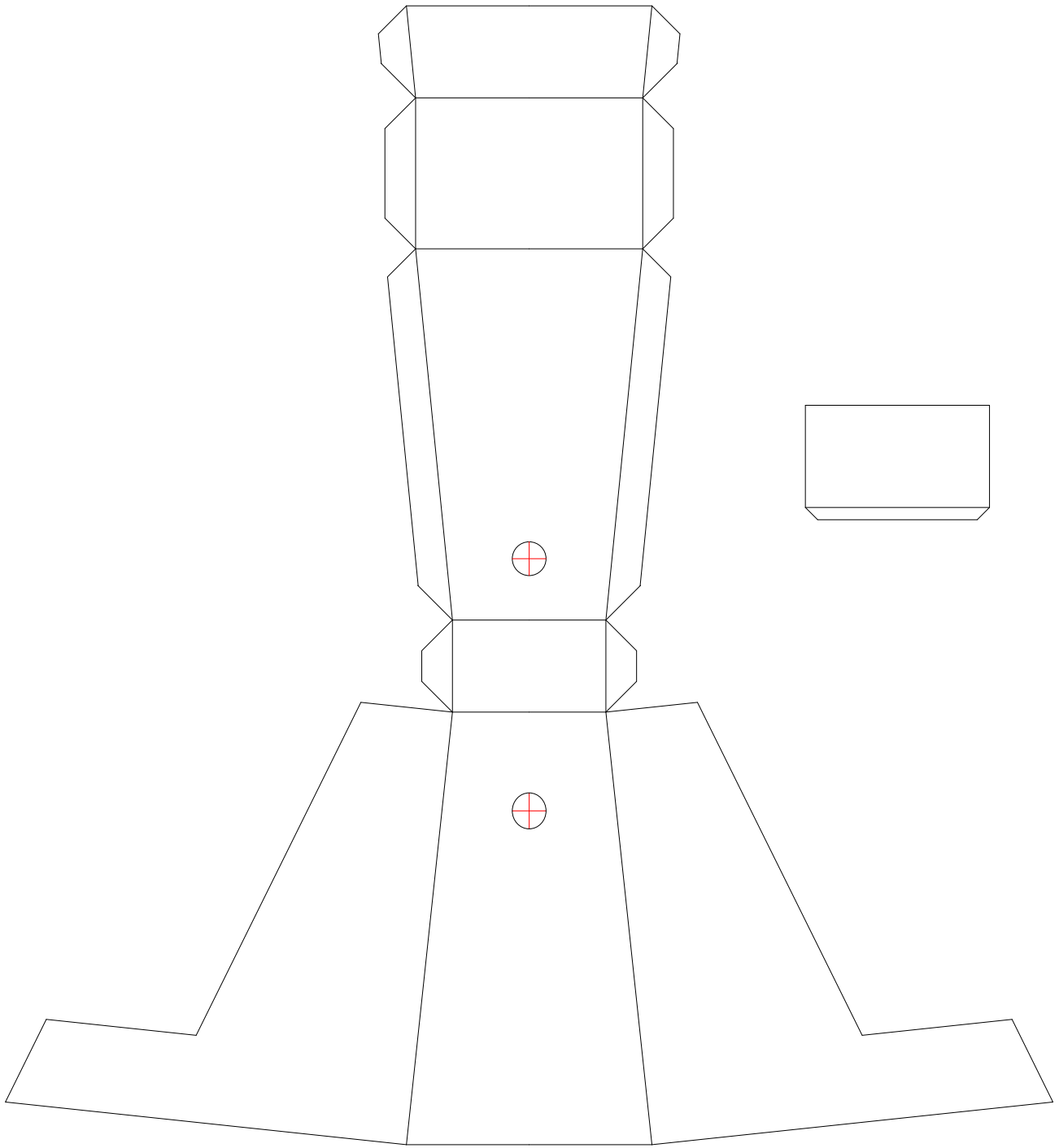

Clerget 7Z
1913